



VESTIBULE CONNECTOR

Features and Benefits

- **Expandability:** allows for unlimited expansion of Western Shelter systems
- **Quickly deployable:** integrates with the existing shelter in only 10 minutes by one trained person and one volunteer
- **Additional square footage:** expands the operational footprint with 56 sq. ft. of usable floor space in a 7' 8" x 7' 4" space with 6" head clearance
- **Flexibility:** connects to an existing shelter at the wall seam or doorway allowing you to expand to given footprint
- **Negative/positive isolation** can be achieved with Isolation upgrade kit
- **Standardized components** provide easy shelter integration

Components

- Aircraft aluminum mainframe assembly constructed of 6063-T5/T6
- Sealable floor
- Integrated vinyl and insulation roof panels
- 3-part environmental partition
- Vinyl storage/transport bags

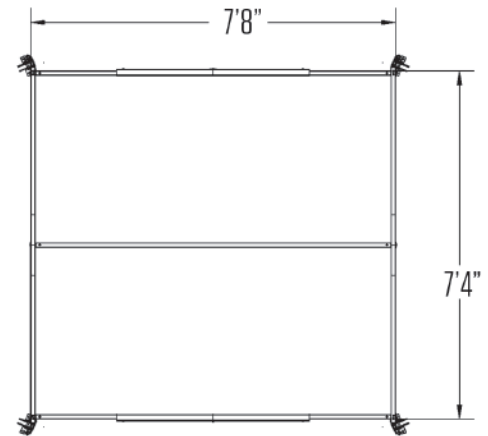

SO-VC8H SPECIFICATIONS

Usable Area	56 ft ²	(5.2 m ²)
Total Weight	65 lb	(29.5 kg)
Total Set Up-Time	10 min / 1 personnel	
Dimensions		
Footprint	7' 8" x 7' 4"	(2.3 x 2.3 m)
Sidewall	6'	(1.8 m)
Peak	6' 7"	(2 m)
Packaged Dimensions	92" x 17" x 12"	(2.3 x 0.4 x 0.3 m)



Vestibule Connector with double doors installed